



CHINO VALLEY INDEPENDENT FIRE DISTRICT FIRE PROTECTION STANDARD

TEMPORARY WATER SUPPLY STANDARD

STANDARD # 129

REVISED 01/02/08 PAGES 4

SCOPE

This standard shall apply to a temporary water supply for developers constructing no more than five single-family dwelling units that are to be used as model homes only.

PURPOSE

The purpose for this standard is to provide an acceptable source of water that meets the intent of Chapter 14 of the California Fire Code, for fire protection in an area where there is no permanent water supply. This standard will allow a developer to erect and display up to five model homes prior to the construction of the production line units and the permanent water system.

REQUIREMENTS

Prior to the delivery of any combustible materials for model homes, to any site that does not have a permanent water system, a temporary water supply may be installed. This water supply may consist of a temporary water line with temporary hydrants approved for use by the Fire Chief. This temporary water line shall be capable of withstanding construction traffic and shall be maintained in an operational manner at all times.

A second acceptable temporary water supply would consist of an approved elevated water tank containing a minimum of 10,000 gallons of water. The tank shall be elevated a minimum of 6'0" above grade. The tank shall be equipped as noted and as shown on the diagram.

The tank shall be located within 150' of the most distant building being protected. A roadway, to the tank, capable of supporting fire apparatus shall be provided and maintained during the time that the tank is being used for temporary water. This tank shall be kept filled at all times and shall be posted "FOR FIRE DEPARTMENT USE ONLY". The letter shall be 6" high, on a contrasting background.

The tank, tank location and access must be approved prior to the delivery of combustible building materials to the site. Under no circumstances shall materials for production homes be delivered to the site until the permanent water system with fire hydrants are in and operational and shall be maintained in this manner at all times during construction.

SPECIFICATIONS

See attached diagram for typical installation.

10,000 GALLON FIRE PROTECTION TANK

- NOTES:
1. All valves to be locked with an approved break away lock.
 2. 4" suction hose end to be locked to tank with break away lock.
 3. Approved tanks to be equipped with sight gauges.
 4. "No parking within 100' " signs to be posted on both sides.
 5. "Fire Dept. use only" signs to be posted on each corner and end
 6. All tanks shall be elevated a minimum 6' above ground.
 7. "Tampering with a Fire Dept. device is a misdemeanor." "California Fire Code 901.8" signs to be posted on both sides.

ALTERNATE EXCEPTIONS

Above ground invasion lines (minimum 6") may be acceptable at the discretion of the Chief. This shall be reviewed on a case-by-case basis. This would only be acceptable as a temporary supply.

The following information shall be provided prior to consideration. A site plan to scale of the project with hydrants plotted. Spacing shall not exceed 300' from any lot as the hose lays on the ground. A letter of intent when the permanent water system will be operational.

The following details below show the acceptable means of invasion line hook-up to an existing water source. Each applicant shall check with the affected water district prior to connection to any public system. The required fire flow for the project shall be met during construction and production. Compliance of this standard is enforced.

This temporary supply standard shall be acceptable in tract development of single-family homes only. The temporary system shall be installed and operational prior to any combustibles being placed on the job site.

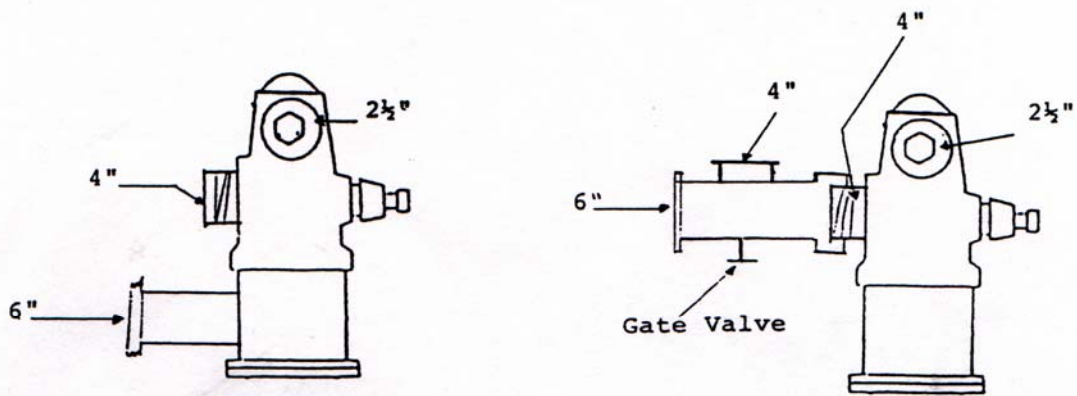

SPECIFICATIONS

See attached diagram for typical installation.

10,000 GALLON
FIRE PROTECTION TANK

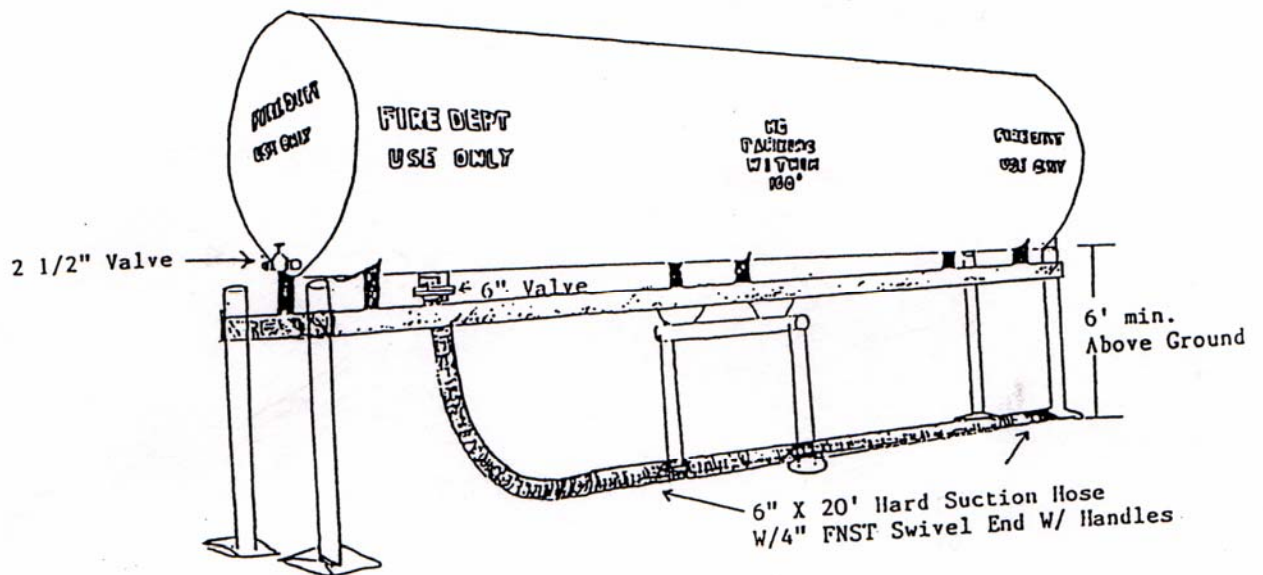

NOTES:

1. All valves to be locked with an approved break away lock.
2. 4" Suction hose end to be locked to tank w/break away lock.
3. Approved tanks to be equipped with sight gauges.
4. "No parking within 100' "signs to be posted on both sides.
5. "Fire Dept. use only" signs to be posted on each corner and end.
6. All tanks shall be elevated a minimum 6' above ground.
7. "Tampering with a Fire Dept. device is a misdemeanor." "California Fire Code 901.8" signs to be posted on both sides.